

AUTOMATIC TRANSMISSION FLUID (A750E/A750F) (From August, 2003)

ADJUSTMENT

4016I-02

1. BEFORE TRANSMISSION FILL

- This transmission requires Toyota Genuine ATF WS.
- It is necessary to refill the transmission with the correct amount of fluid.
- The vehicle must remain level while adjusting the transmission fluid level.
- On vehicles equipped with active suspension, turn the suspension control switch OFF if it is necessary to jack up the vehicle with the engine running.

2. TRANSMISSION PAN FILL

- (a) Remove the refill plug and overflow plug.

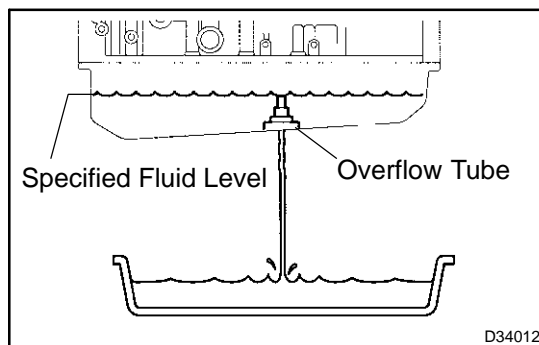
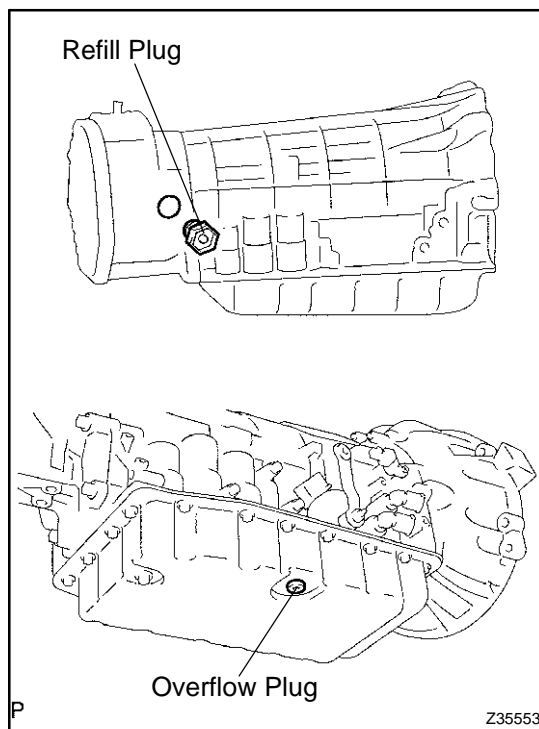

- (b) Fill the transmission through the refill hole until fluid begins to trickle out of the overflow tube.
- (c) Reinstall the overflow plug.

3. TRANSMISSION FILL

- (a) Fill the transmission with the correct amount of fluid as listed in the table below.
- (b) Reinstall the refill plug to avoid fluid splash.

Repair	Fill Amount
Transmission pan and drain plug removal	1.3 L (1.37 US qts, 1.14 Imp qts)
Transmission valve body removal	3.9 L (4.12 US qts, 3.43 Imp qts)
Torque converter removal	5.3 L (5.60 US qts, 4.66 Imp qts)
Entire transmission assembly	5.3 L (5.60 US qts, 4.66 Imp qts)

HINT:

If you cannot add the listed amount of fluid, do the following:

- Install the refill plug.
- Allow the engine to idle with the air conditioning OFF.
- Move the shift lever through entire gear range to circulate fluid.
- Wait for 30 seconds with the engine idling.
- Stop the engine.
- Remove the refill plug and add fluid.
- Reinstall the refill plug.

4. FLUID CIRCULATION

- (a) Allow the engine to idle with the air conditioning OFF.
- (b) Move the shift lever through entire gear range to circulate fluid.

5. FLUID TEMPERATURE CHECK

NOTICE:

The fluid temperature can be confirmed by checking the indicator light in the meter or by using the intelligent tester. When using the intelligent tester, it is necessary to change to temperature detection mode in order to idle the vehicle appropriately.

- (a) When using intelligent tester:
 - (1) Turn the ignition switch OFF.
 - (2) Connect the hand-held tester to the DLC3.
 - (3) Turn the ignition switch ON.
 - (4) Enter the following menus: DIAGNOSIS / OBD/ MOBD / ACTIVE TEST / TC/E1.
 - (5) Enter the following menus: DIAGNOSIS / OBD/ MOBD / DATA LIST / A/T OIL TEMP 1.
 - (6) Check ATF temperature.

NOTICE:

- If the fluid temperature is below 46°C (115°F), proceed to the next step. Recommended fluid temperature is 36°C (97°F) or less.
- If the fluid temperature is 46°C (115°F) or more, turn the ignition switch OFF and wait until the fluid temperature is below 36°C (97°F).

- (7) According to the display on the intelligent tester, perform the active test "TC/E1".
- (8) Start the engine.

HINT:

Indicator lights of the combination meter blink to output DTCs when TC and TE1 are connected.

NOTICE:

Check that electrical systems such as the air conditioning system, audio system and lighting system are off.

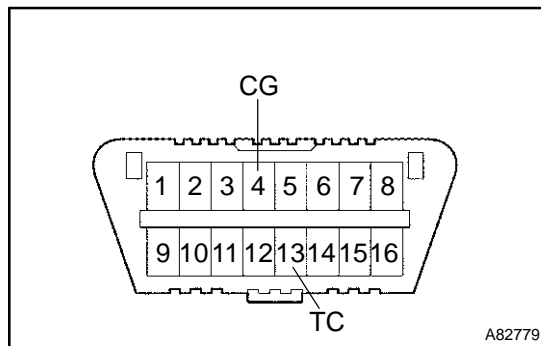

- (b) When not using the intelligent tester (Using A/T OIL TEMP indicator):

- (1) Connect terminals between CG (4) and TC (13) of the DLC3 using SST.

SST 09843-18040

- (2) Start the engine.

HINT:

Indicator lights of the combination meter blink to output DTCs when TC and TE1 are connected.

NOTICE:

Check that electrical systems such as the air conditioning system, audio system and lighting system are off.

- (c) Slowly move the shift lever from P to L, and then return the shift lever to P.

HINT:

Slowly move the shift lever to circulate the fluid through each part of the transmission.

- (d) Move the shift lever to D, and quickly move it back and forth between N and D (once within 1.5 seconds) for six seconds. This will activate the fluid temperature detection mode.

Standard condition:

A/T OIL TEMP warning light remains illuminated for 2 seconds and then turns off.

- (e) When using the intelligent tester:
 - (1) Return the shift lever to P and press OFF on the active test display.
- (f) When not using the intelligent tester:
 - (1) Return the shift lever to P and remove the SST from the DLC3.
- (g) Allow the engine to idle until the fluid temperature reaches 36 to 46°C (97 to 115°F).
- (h) The A/T OIL TEMP warning light will come on again when the fluid temperature reaches 36°C (97°F) and will blink when it exceeds 46°C (115°F).

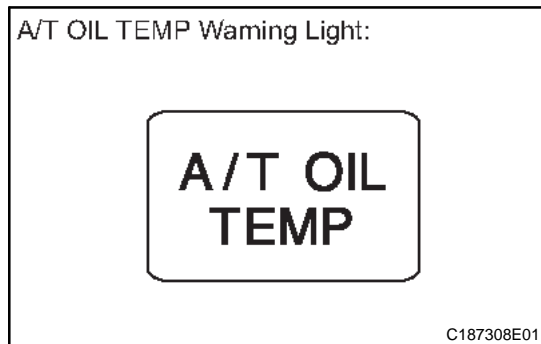

Indicator Indication of ATF Temperature

Below Proper Temperature	Proper Temperature	Higher than Proper Temperature
Data list: A/T OIL TEMP1 36°C (97°F) or less	Data list: A/T OIL TEMP1 36 to 46°C (97 to 115°F)	Data list: A/T OIL TEMP1 46°C (115°F) or higher
A/T OIL TEMP light Turns off	A/T OIL TEMP light Turns on	A/T OIL TEMP light Blinking

NOTICE:

Perform the fluid level inspection while the indicator light is on.

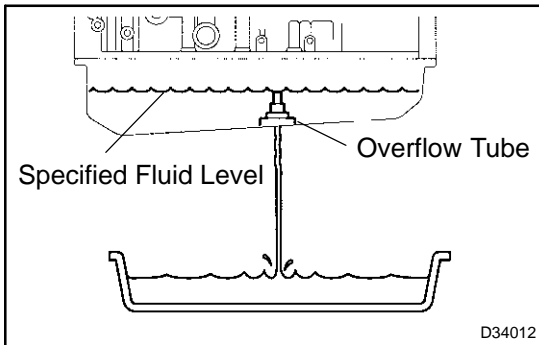

6. FLUID LEVEL CHECK

NOTICE:

The fluid temperature must be between 36°C (97°F) and 46°C (115°F) to accurately check the fluid level.

- (a) Remove the overflow plug with the engine idling.
- (b) Check that the fluid comes out of the overflow tube.

If fluid does not come out, proceed to step 7.

If fluid comes out, wait until the overflow slows to a trickle and proceed to step 8.

7. TRANSMISSION REFILL

- (a) Install the overflow plug.
- (b) Stop the engine.
- (c) Remove the refill plug.
- (d) Add 0.4 liters (0.42 US qts, 0.35 Imp qts) of fluid.
- (e) Allow the engine to idle and wait for 10 seconds.
- (f) Proceed to step 6.

8. COMPLETE

- (a) Install the overflow plug with a new gasket.
Torque: 20 N·m (205 kgf·cm, 15 ft·lbf)
- (b) Stop the engine.
- (c) Install the refill plug with a new gasket.
Torque: 39 N·m (400 kgf·cm, 29 ft·lbf)

-MEMO-

-MEMO-

-MEMO-

-MEMO-