

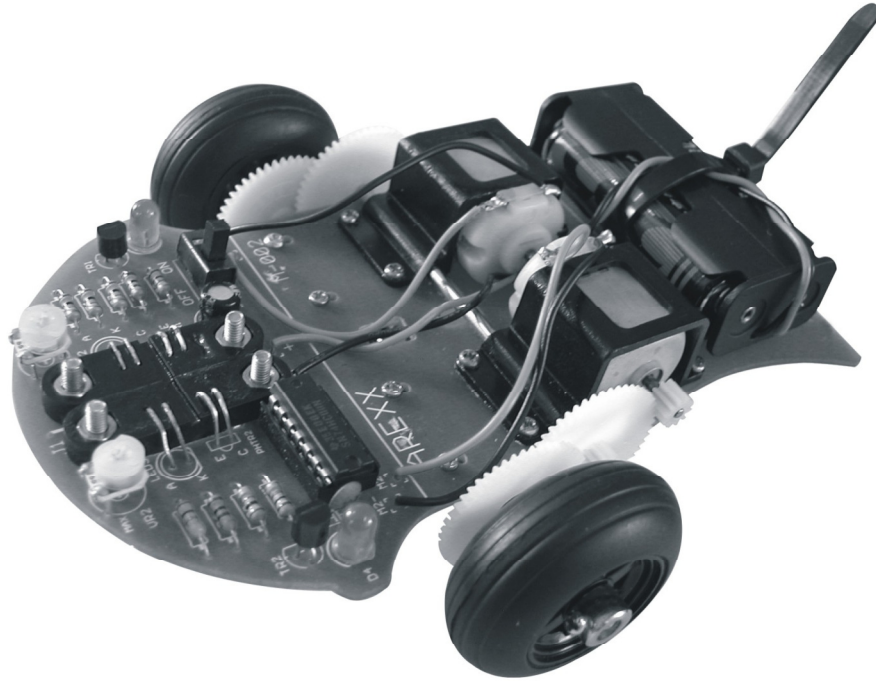

Line Tracing Car



All rights reserved:

Reprinting any of this instruction manual without our permission is prohibited. The specifications, forms, contents of the product are subject to change without prior notice. We are not liable for disadvantage or damage caused by improper use or assembly.

<http://juallinefollowermanual.blogspot.com/>

Instruction :

This product takes the principle of light sensing. The two motors are activated by the two light sensors on the front which can sense the light they catch. Only If you paint a black line on the white paper and then turn on the switch ,The line tracing car can track the black line that you paint.

Specification:

Power source: 3v (AA battery X 2pc)
Power consumption: MAX :100mA, MIN:60mA
Size: 140x125x40mm
Net weight: 170g



Precaution:

- When you open the parts the return right will be disposed.
- Read carefully before you start assembly the instruction manual.
- Be carefully with tools
- Keep this product out of reach of children and do not build this kit when children are in the neighbourhood, the tools and parts are dangerous for children
- Check the polarity of the battery.
- Keep the batteries dry, when the line tracing car gets wet, remove the batteries and let it dry for some time.
- Remove the batteries when you are not using the product for a period of time.

Necessary tools:

We advise you to read carefully the operation manual before assembly.

Please assemble this education model according to instruction manual, so that you can avoid mistake. If you study the assembly indication diagram carefully, then you can assemble a completed line tracing car immediately.

You must use these tools as follows before assembly, so you can assemble without difficulties.



HEX

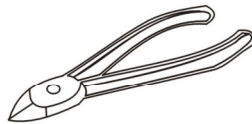

Diagonal Cutter

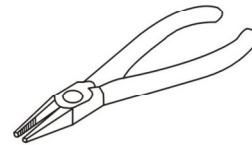

Long Nose Plier

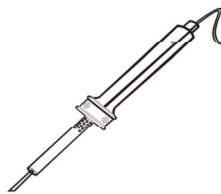

Solder Iron

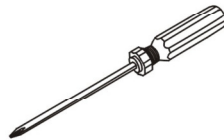



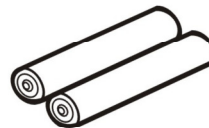







Screwdriver

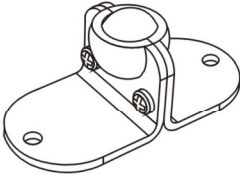
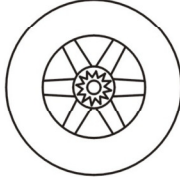
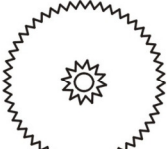
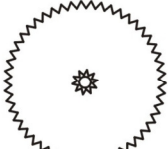

AA Dry Cell

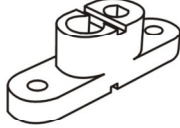
Part list

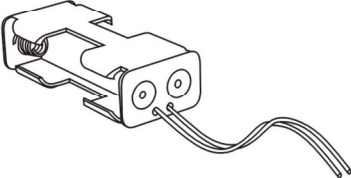
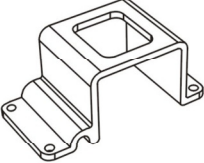
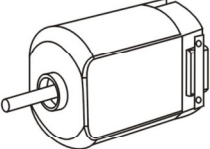
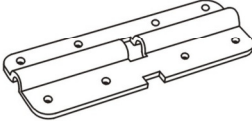
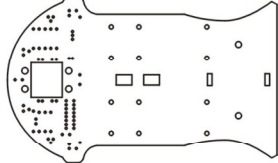
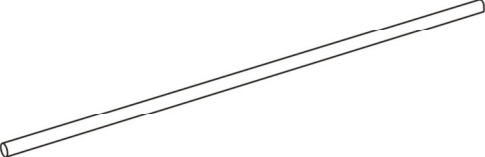
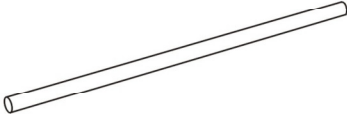
 M2×8 Screw ① 12PCS	 M2 Nut ② 12PCS	 M3×8 Screw ③ 6PCS	 M3 Nut ④ 6PCS	 M3×5 Screw ⑤ 2PCS
 Tubular Nut ⑥ 4PCS	 Kimi Screw ⑦ 2PCS	 Universal Wheels ⑧ 1PCS	 Black rubber wheel ⑨ 2PCS	
 Gear① (Main gear50, Cleputy gear12) ⑩ 2PCS	 Gear② (Main gear50, Cleputy gear10) ⑪ 2PCS	 Gear③ ⑫ 2PCS	 Shacing plastic parts ⑬ 2PCS	
 Black belt ⑭ 1PCS		 Brattary box ⑮ 1PCS		
 Fixed motor plastic ⑯ 2PCS	 Motor ⑰ 2PCS	 Fixed Axis plastic ⑱ 1PCS	 PCB ⑲ 1PCS	
 Metal Axis $\phi 3 \times 124\text{mm}$ ⑳ 1PCS		 Metal Axis $\phi 3 \times 78\text{mm}$ ㉑ 1PCS		

electronic components

②②



Resistor

<input type="checkbox"/> R1	100Ω	Brown Black Brown Golden
<input type="checkbox"/> R2	1K	Brown Black Red Golden
<input type="checkbox"/> R3	1K	Brown Black Red Golden
<input type="checkbox"/> R4	100Ω	Brown Black Brown Golden
<input type="checkbox"/> R5	1K	Brown Black Red Golden
<input type="checkbox"/> R6	100Ω	Brown Black Brown Golden
<input type="checkbox"/> R7~R9	1K	Brown Black Red Golden



PCB Mark



Good soldering

②③



Variable resistor

VR1.VR2
500K Ω



PCB Mark

Good soldering 

②④

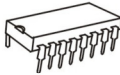

IC

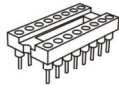

IC Socket

IC1

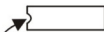

PCB Mark

Pay attention to orientation

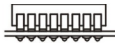

Good soldering

②⑤



Switch

SW



PCB Mark



Good soldering

②⑥



LED
(RED)

LED1~LED4

②⑦



photographic tube
(transparent)

PHTR1
PHTR2



PCB Mark



Good soldering

②⑧

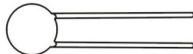

Ceramic capacitor

C2 0.1uF



PCB Mark

Good soldering 

②⑨



Electrolytic capacitor

C1 100uF



PCB Mark



Good soldering

③⑩



Transistor

TR1.TR2

PCB Mark



Good soldering



③①



Wire 4PCS
Two red and black wire each (10CM)

The installation process:

The installation of electronic components:

Wielding PCB shows clearly the position of each part, please refer to electronic diagram and installation instruction diagram for more information.

We always start to solder the lowest parts, usually the resistor is first, then capacitance. We advise to cut the component wires directly after soldering so they will be out of the way when you start soldering other parts.

Before soldering, we advise to install components (for example transistor, IC, diode), in this way, when some parts do not fit properly, you can reinstall.

Suggestion:

Electrolytic capacitor, LED, photographic tube and IC have polarity, you must pay attention to the polarity when soldering.

Warning:

Do not solder IC directly, when you are soldering IC, it is better to use IC socket to avoid mistake. As after soldering, it is difficult to remove.

Attention:

You should align IC pins with a flat nose plier or bend them all together when all pins rest on the table



You must make sure the PCB is no electricity when soldering. It is not enough to only turn off the switch of battery, you must remove the battery.

Schematic

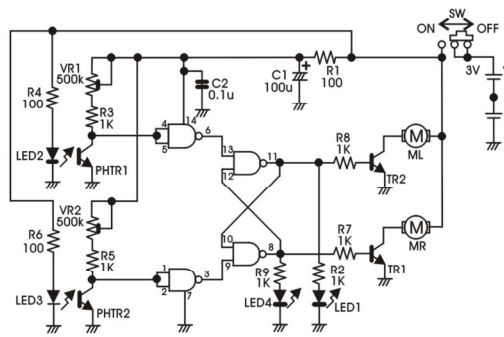

PCB soldering

Please solder each part according to instruction

1.

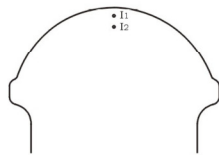

Wire \rightarrow Bend $\left[\right]$

Cutted wire can be used instead of wire

Solder the I1 and I2

2.

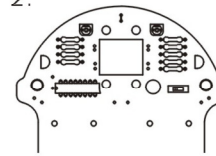

Solder completed PCB

The assembly of black shielding-light plastic part and diode

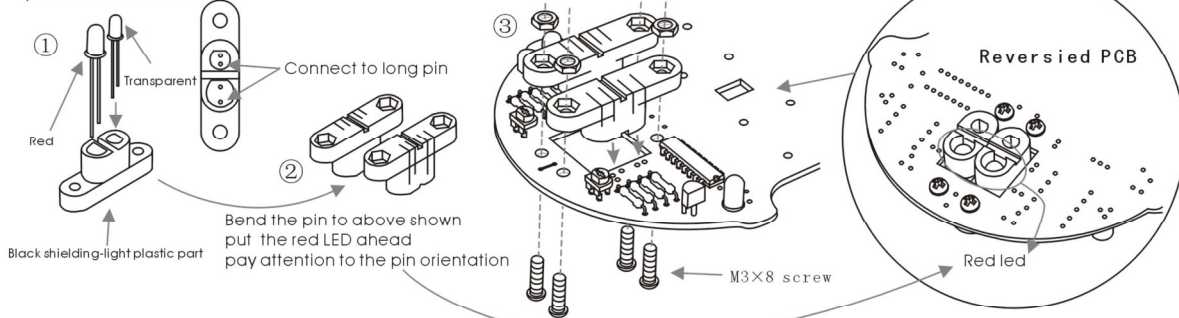

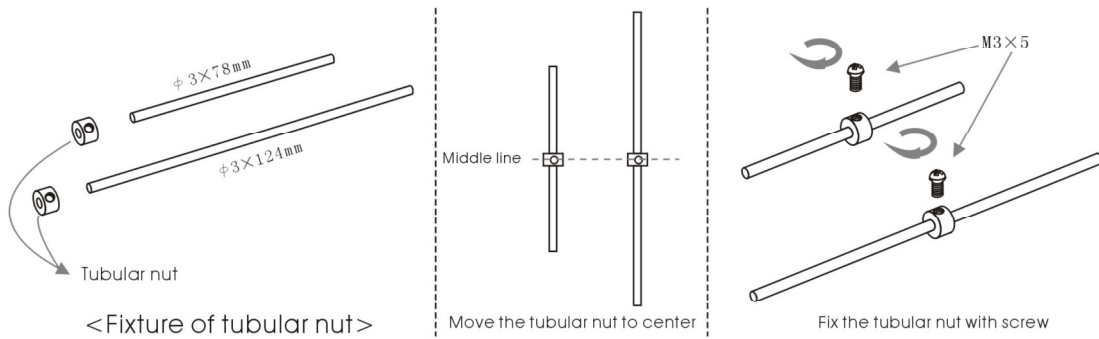

< Fixture of tubular nut >

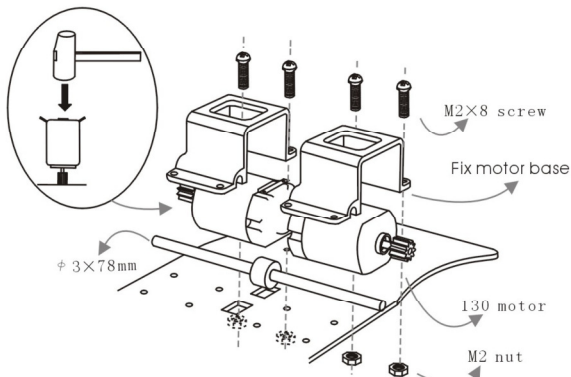

< Assembly of motor and short shaft >

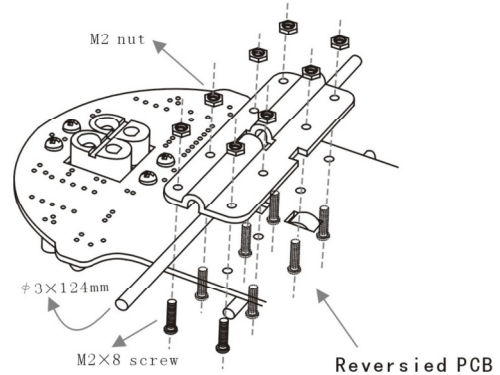

< Assembly of long shaft >

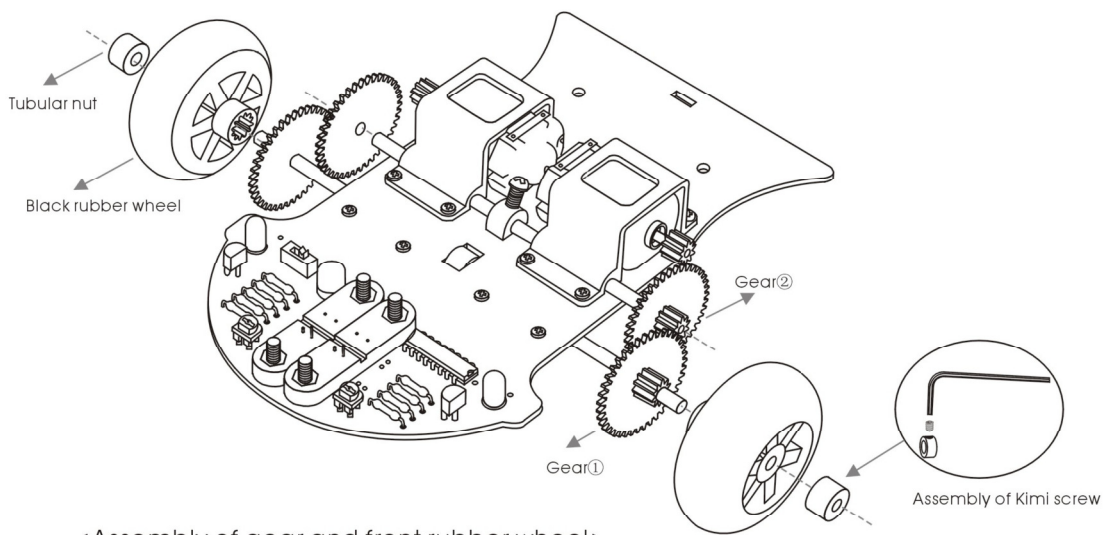

< Assembly of gear and front rubber wheel >

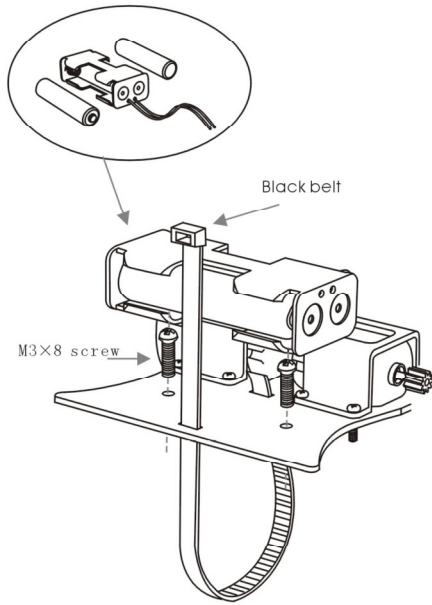

<Assembly of battery box>

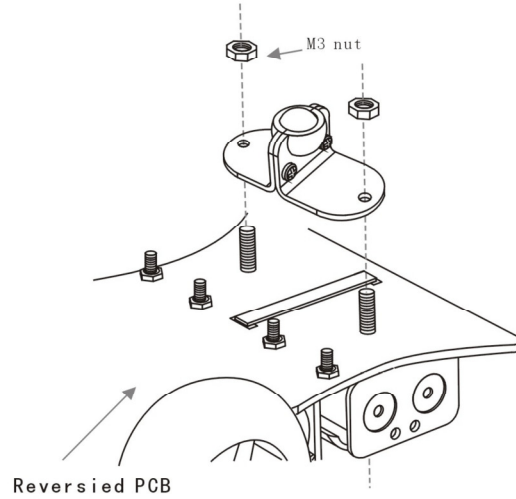

<Assembly of universal wheel>

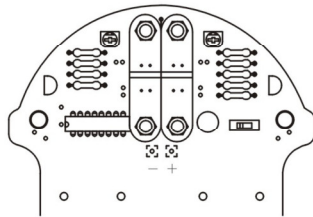

Connect to battery and pay attention to the polarity
red line is anode and black line is cathode

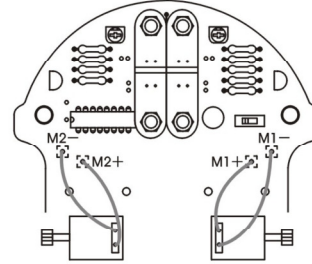

Solder the motor with wire
the red point on the motor is anode

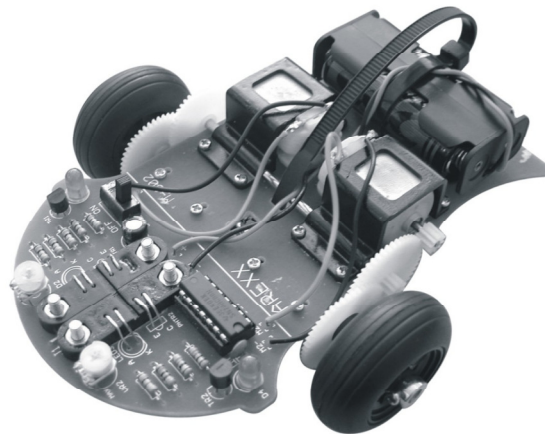

<Completed drawing>

Debug:

After assembly, now you can debug your line tracing car; first you should paint a thick black line on the white paper (circuit is better), then put the paper on the table, turn on the switch, put precisely the sensing diode to the black line, in this way it can run along the black line.

Check here when it is not operated correctly.

Problem	Check
Motor can not be activated	<ul style="list-style-type: none">• Check the life of the battery• Check the polarity of the battery• Check the wiring of the motor
It can not run along the Black line	<ul style="list-style-type: none">• Check whether the black line is too thin (advise to 3cm width)• Check whether the black line is deep black• Check whether the variable resistor is adjusted accordingly• Check the polarity of the light sensing diode.• Check whether the light is too strong around.• Check the polarity of the motor.